

A Smart Thermal Block Diagram Tool

**Glenn Tsuyuki, Robert Miyake,
Ramachandra Manvi, & Kyle Dodge
Jet Propulsion Laboratory
California Institute of Technology
Pasadena, CA
August 20, 2008**

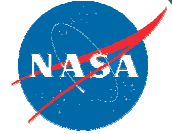

Outline

- Problem Statement
- Solution Approach & Requirements
- Tool Overview Using a Simple Example
- Conclusions

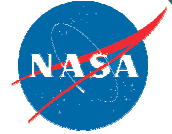

Problem Statement (1/2)

- A critical tool for identifying subsystem architecture is the block diagram
- No associative database capability to define types and quantities of subsystem resources.
- A protracted and manual process must occur to tabulate these resources and transfer them to appropriate cost estimating tools.

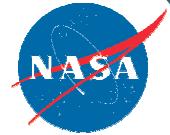

Problem Statement (2/2)

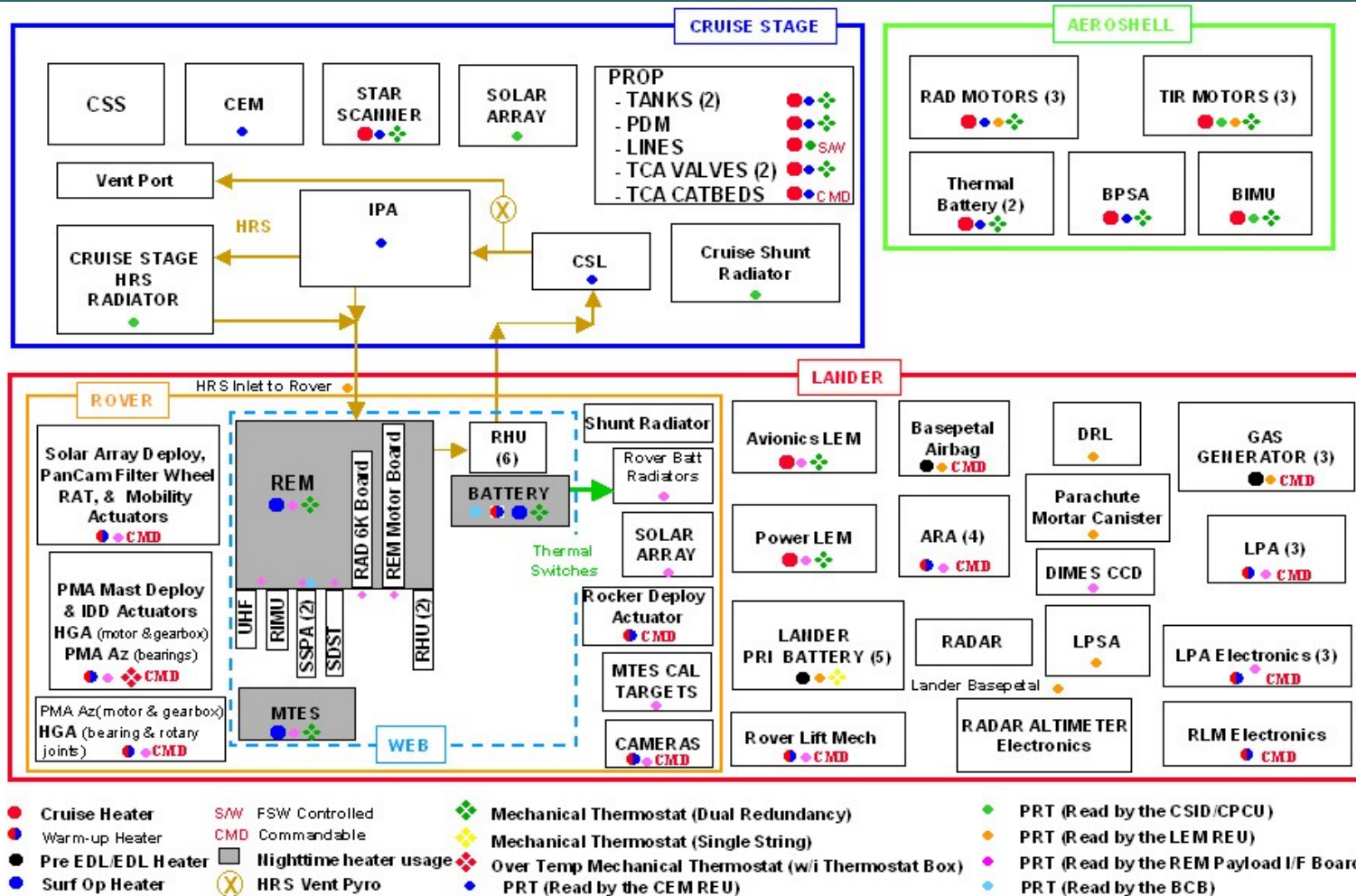

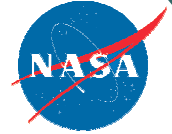

Solution Approach (1/3)

- Block diagram templates for typical JPL missions and instruments (e.g., Orbiters, Landers, Rovers) will be developed
- User will have capability to select thermal subsystem resources as icons and locate each icon in appropriate engineering subsystem or payload element

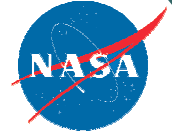

Solution Approach (2/3)

- User will have capability to edit thermal block diagram as needed
- Block diagram tool produces graphical depiction of thermal subsystem, compiles thermal subsystem resources, and determines mass & cost estimates using a JPL Thermal Cost Database

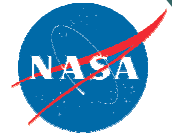

Solution Approach (3/3)

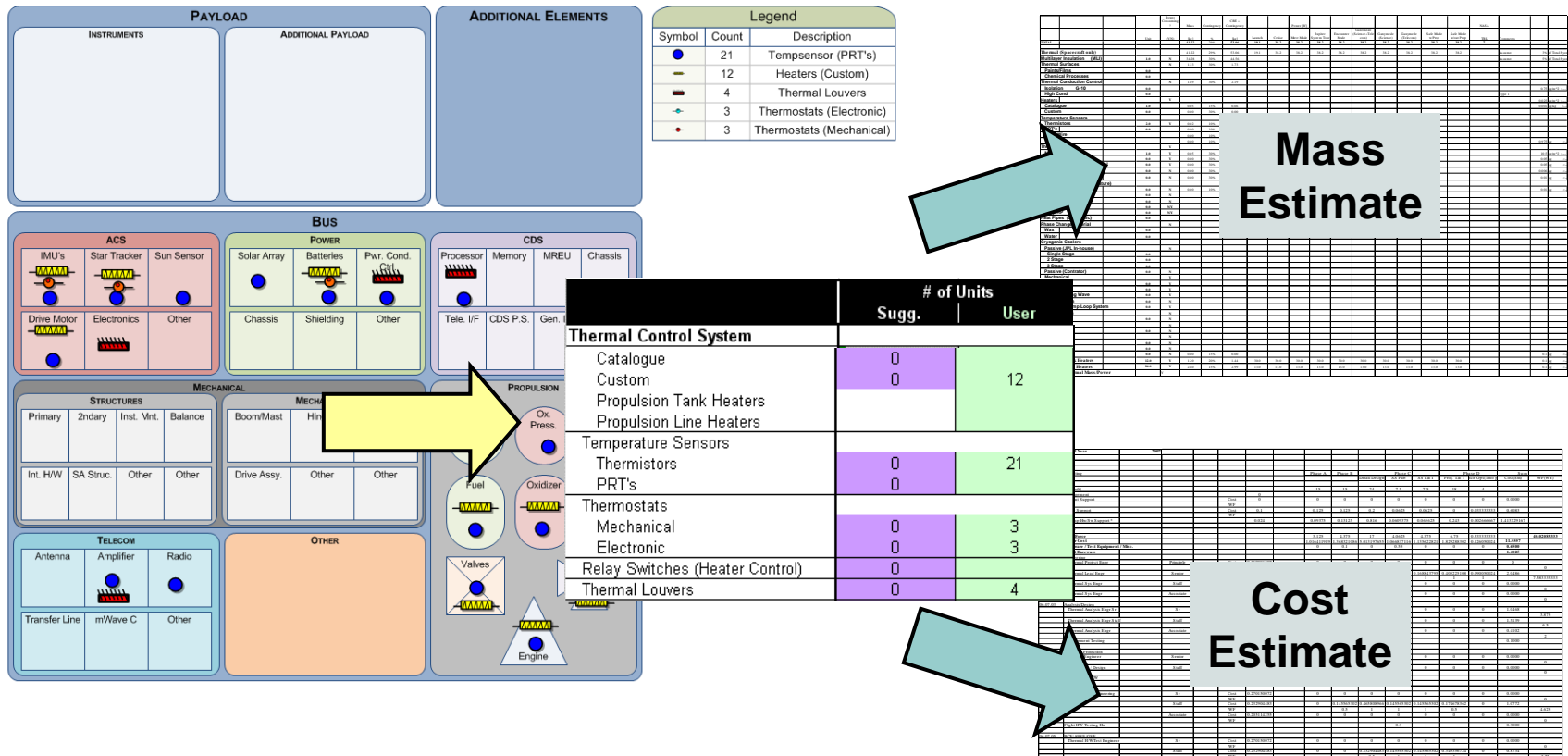

Automated compilation of thermal hardware resources that is then used for subsystem costing & mass estimation

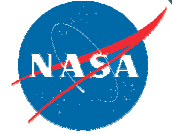

Requirements (1/2)

- Use existing COTS software that can be adapted to our purpose
 - MS Visio is an example of such software
- The tool shall be compatible with Team X workstations
- Block diagram development shall consider typical JPL missions & instruments (e.g., Orbiters, Landers, Rovers)
- References to engineering subsystems & payload elements shall be consistent with the JPL standard WBS

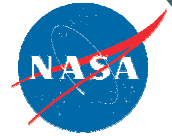

Requirements (2/2)

- Thermal subsystem resources shall be mapped one-to-one with the existing JPL Thermal Cost Database
- Output shall be directly usable or importable into the Thermal Cost Estimating Tool

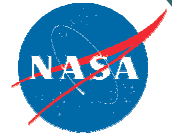

Block Diagram for Earth Orbiter

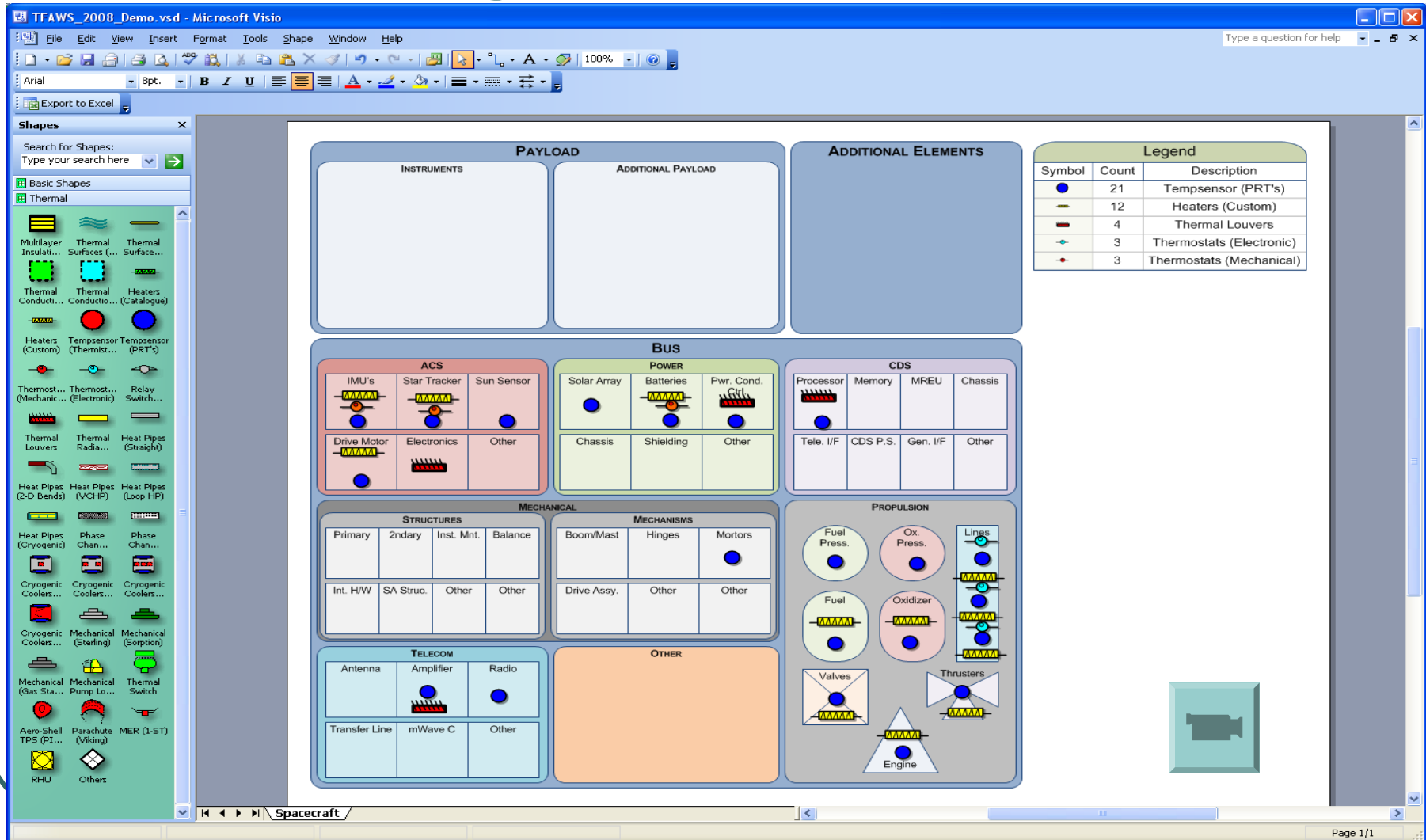

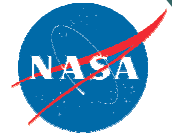

Thermal Control Elements Used

	# of Units	
	Sugg.	User
Thermal Control System		
Catalogue	0	12
Custom	0	
Propulsion Tank Heaters		
Propulsion Line Heaters		
Temperature Sensors		
Thermistors	0	21
PRT's	0	
Thermostats		
Mechanical	0	3
Electronic	0	3
Relay Switches (Heater Control)	0	
Thermal Louvers	0	4

Thermal Cost Tool Hardware Mass Estimate

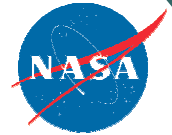

	Specific Masses		CBE	Cont.	PBE
	Sugg.	User			
Thermal Control System			15.80 kg	26%	19.9 kg
Heaters					
Catalogue					
Custom	0.05 kg/unit	0.05 kg/unit	0.60 kg	30%	0.78 kg
Propulsion Tank Heaters					
Propulsion Line Heaters					
Temperature Sensors					
Thermistors	0.02 kg/unit		0.42 kg	15%	0.48 kg
PRT's					
Thermostats					
Mechanical	0.02 kg/unit		0.06 kg	15%	0.07 kg
Electronic	0.01 kg/unit		0.03 kg		0.03 kg
Relay Switches (Heater Control)					
Thermal Louvers	0.98 kg/unit	0.98 kg/unit	3.92 kg	15%	4.51 kg

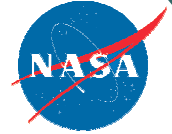

Thermal Hardware Cost

- The same hardware tally information was imported into a JPL thermal hardware cost database & an estimate was computed
- Results were withheld due to the proprietary nature of this information

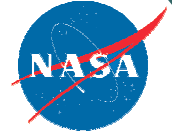

Conclusions

- A block diagram tool was developed & it produces graphical depiction of thermal subsystem, compiles thermal subsystem resources, and determines mass & cost estimates using the JPL Thermal Mass & Cost Databases
- This results in a rapid & controlled process for Pre-Phase A thermal design conceptual definition