



## An Advanced Loop Heat Pipe for Cryogenic Applications

Jentung Ku  
NASA/GSFC

Triem Hoang  
TTH Research Inc.

Presented By  
Jentung Ku



**TFAWS**  
ARC • 2016

[Thermal & Fluids Analysis Workshop](#)  
[TFAWS 2016](#)  
[August 1-5, 2016](#)  
[NASA Ames Research Center](#)  
[Mountain View, CA](#)

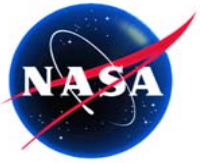

# Outline

- **Traditional LHP for Spacecraft Applications**
- **Technical Challenges in CLHP Development**
- **Advanced CLHP with a Secondary Evaporator and a Hot Reservoir**
  - **Operational Principles**
- **An Example: Hydrogen CLHP**
- **Summary and Conclusions**

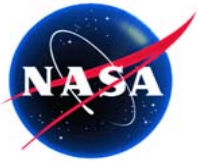

# Traditional Loop Heat Pipe

- **Application**
  - Transport heat from a heat source to a heat sink over a large distance
- **No External Pumping Power**
  - Waste heat provides the driving force.
- **No Moving Parts**
- **Robust Operation**
  - **Passive**
  - **Self-regulating**
- **High Pumping Capability**
- **High Thermal Conductance**
- **Smooth-walled and flexible transport lines provide flexibilities for design, integration and testing.**

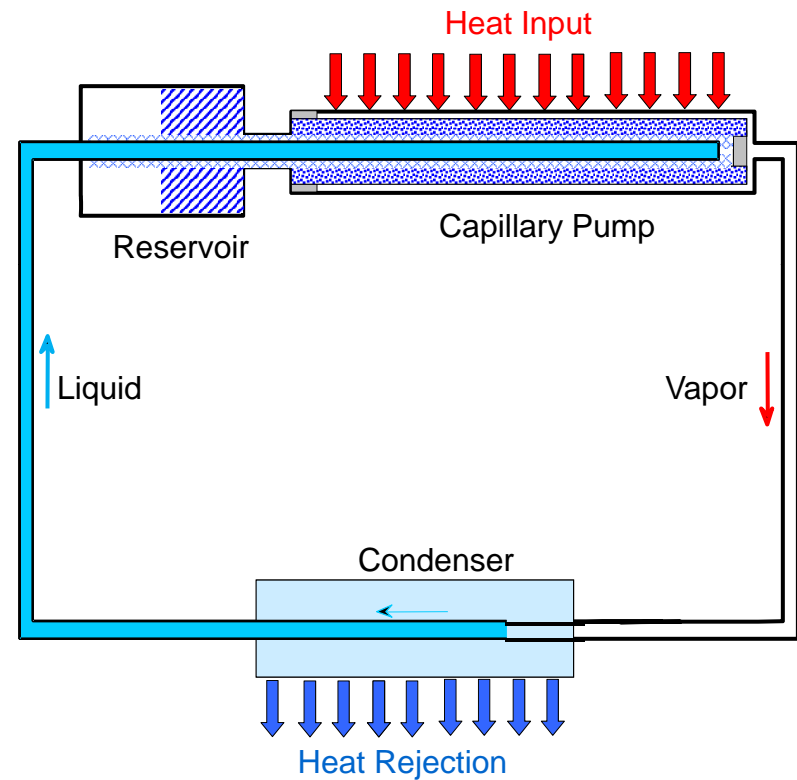

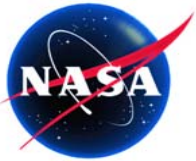

# Traditional Cryocooling of Sensors

## INDIVIDUALLY COOLED SENSORS

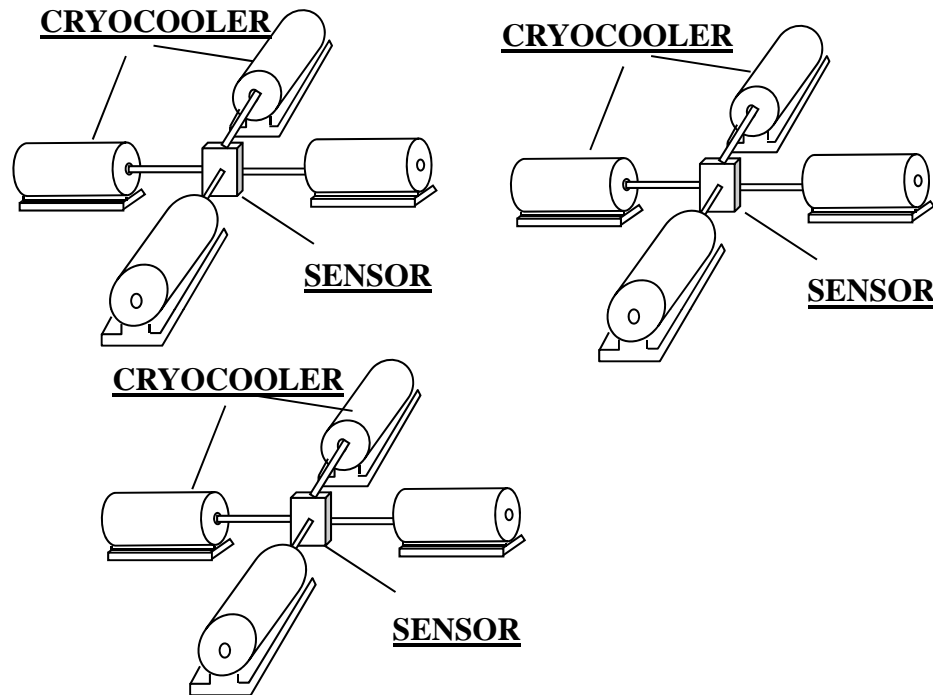

3 SENSORS,  
12 CRYOCOOLERS

- **Unwanted vibration induced by the mechanical cryocoolers may cause unacceptable jitter to the telescope.**
- **Packaging and integration are difficult in tight spaces especially when two or more cryocoolers are needed for redundancy.**
- **Heat parasitics from one inactive cryocooler may overload the active ones.**

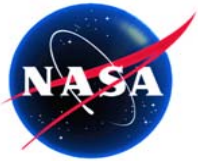

# Cooling with Cryogenic LHP

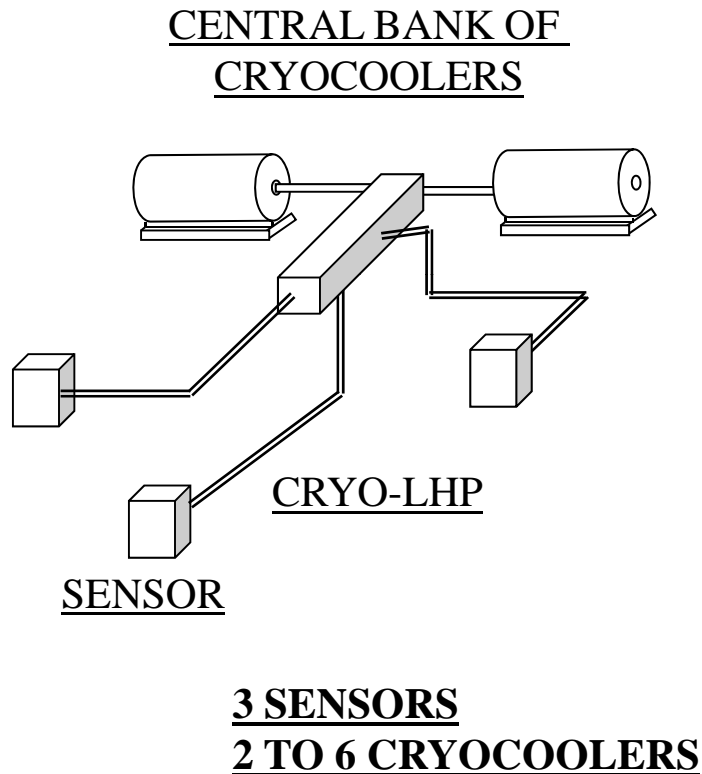

- **Jitter-free observations of the telescope at a target may prove invaluable for most space missions.**
- **A flexible heat transport device is therefore needed to provide a cryogenic link between the IR sensors and cryocoolers.**
- **CLHP with flexible transport lines provides the needed vibration isolation.**

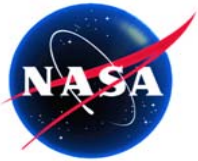

# Technical Challenges in CLHP Development

- **Coefficient of thermal expansion mismatch between the wick and the evaporator shell**
- **Containment of the system pressure at ambient temperature**
- **Start-up from an initially supercritical state**
- **Parasitic heat gains along the liquid return line**

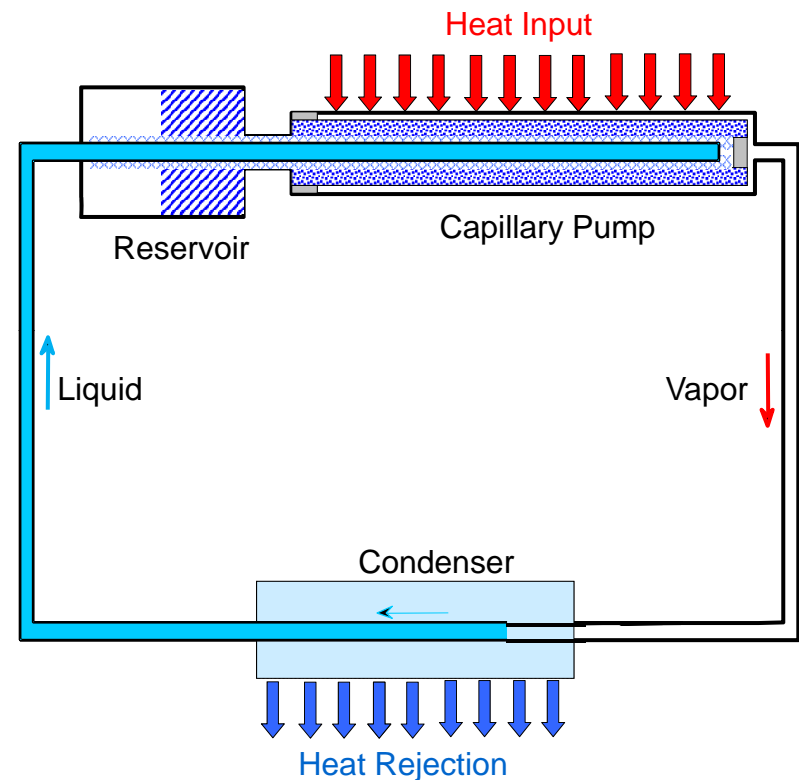

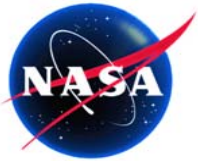

# Mismatch of Coefficients of Thermal Expansion

- A tight seal is required in order to prevent the vapor at the outer surface of the primary wick from penetrating into the liquid core of the evaporator.
- A mismatch in the CTEs between the primary wick and the evaporator shell over the range from the ambient temperature to cryogenic temperature could affect the required tightness of the seal between the two components.

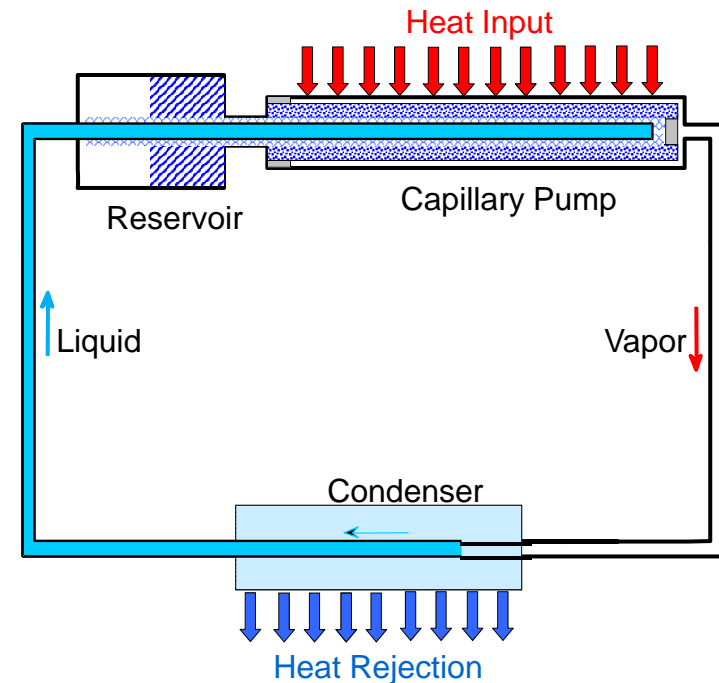

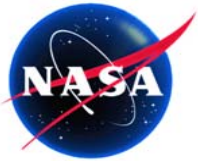

# Pressure Containment

- A minimum amount of the working fluid is required in order for the CLHP to operate properly over the desired cryogenic temperature range.
- At ambient temperature, the gas pressure will be very large, resulting in pressure containment issues.
- More importantly, if the system pressure is greater than the critical pressure of the working fluid, startup of the CLHP becomes impossible.

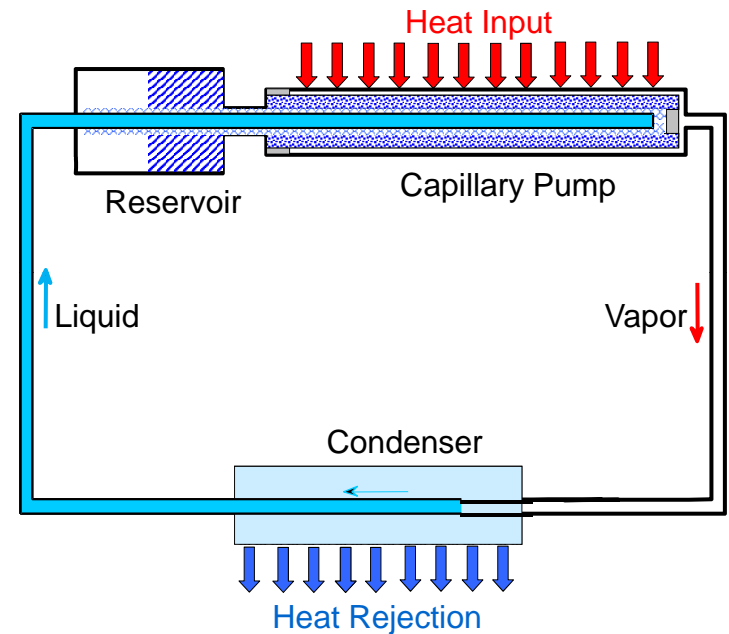



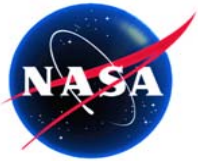

## Start-up from an Initially Supercritical State

- **Liquid must be present in the capillary pump prior to startup.**
- **No liquid will be formed if the system pressure is greater than the critical pressure regardless how low the component temperature is.**
- **Below the critical pressure, liquid will be formed at places where the temperature is lower than the critical temperature.**

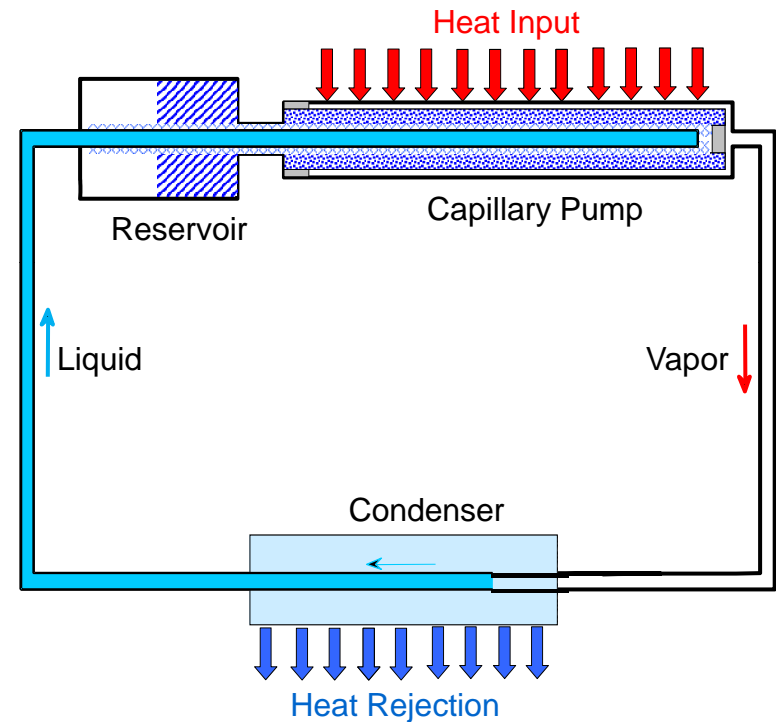

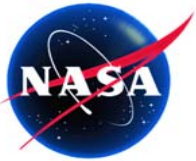

## Parasitic Heat Gains Along the Liquid Line

- There is an inherent heat leak from the evaporator to the reservoir, and the reservoir can also gain heat from ambient.
- All heat gains must be compensated for by the cold liquid returning from the condenser.
- High parasitic heat gains along the liquid line will raise the returning liquid temperature, and ultimately the reservoir temperature.
- The CLHP cannot operate when the reservoir temperature is greater than the critical temperature.

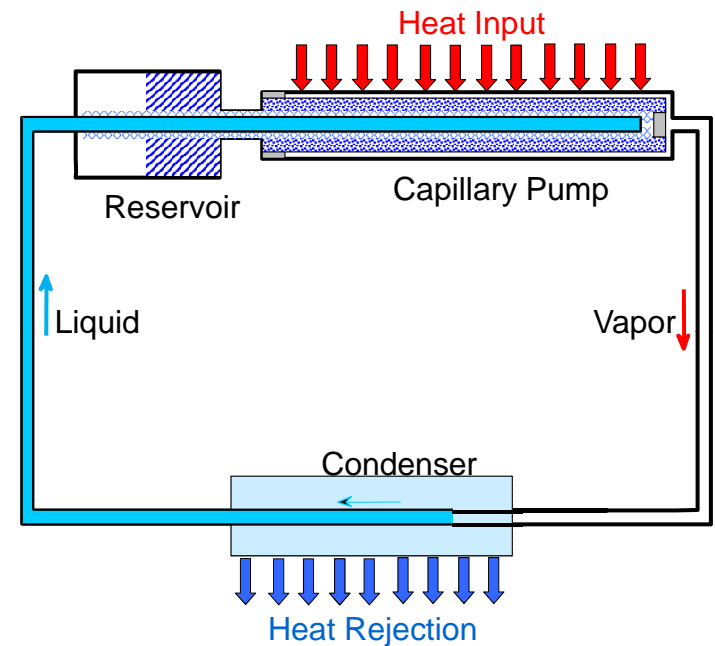

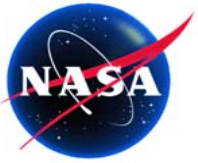

# LHP Energy Balance LHP

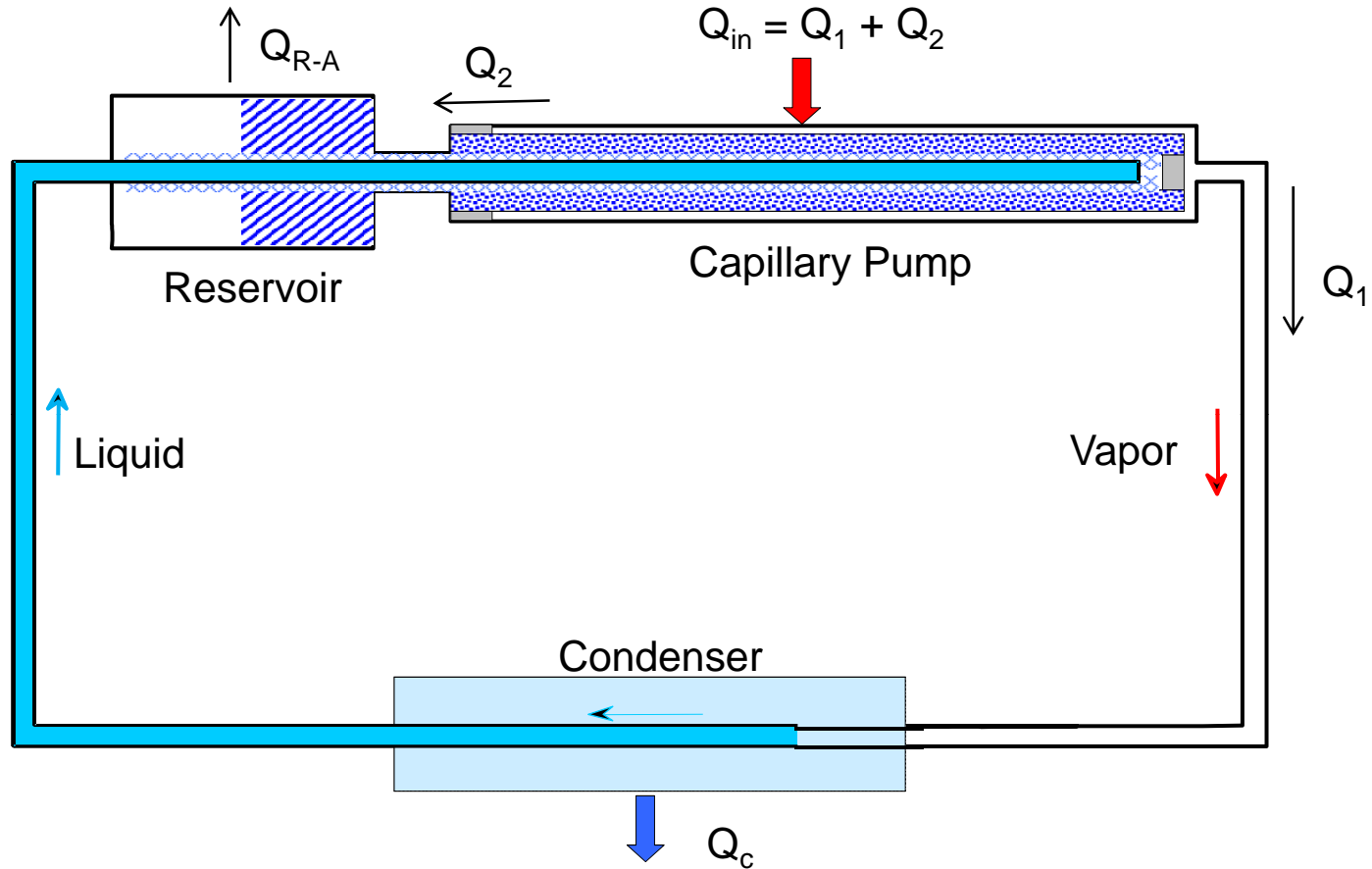

$$\begin{cases} \dot{Q}_1 = \dot{Q}_c \\ \dot{Q}_2 = \dot{m} c_p (T_{SAT} - T_{IN}) + \dot{Q}_{R-A} \end{cases}$$

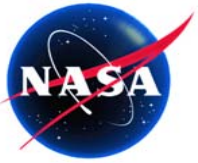

# LHP Operating Temperature

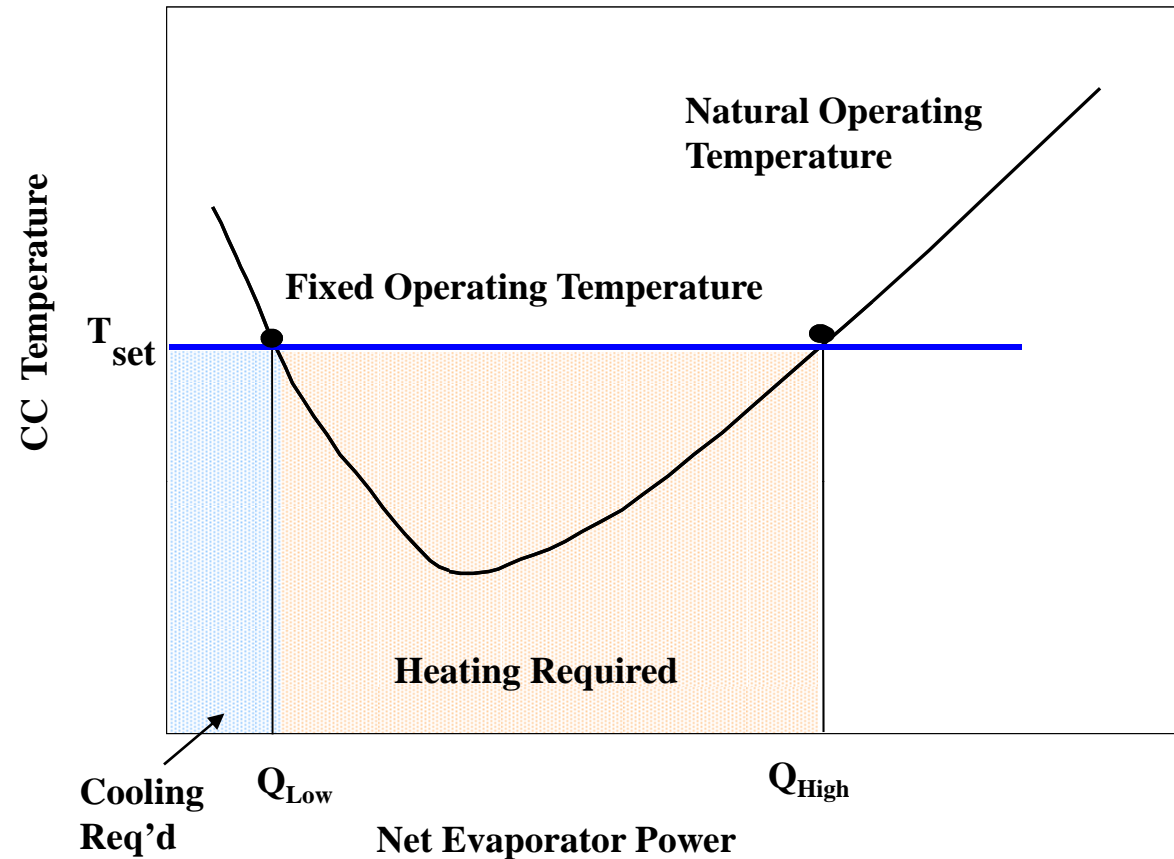

- LHP operating temperature,  $T_{Sat}$ , is determined by energy balance between heat leak and liquid subcooling.
- $T_{Sat}$  changes with the evaporator power, condenser sink temperature, and ambient temperature.

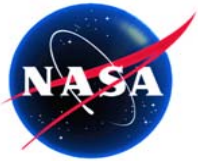

# Concept of Advanced LHP

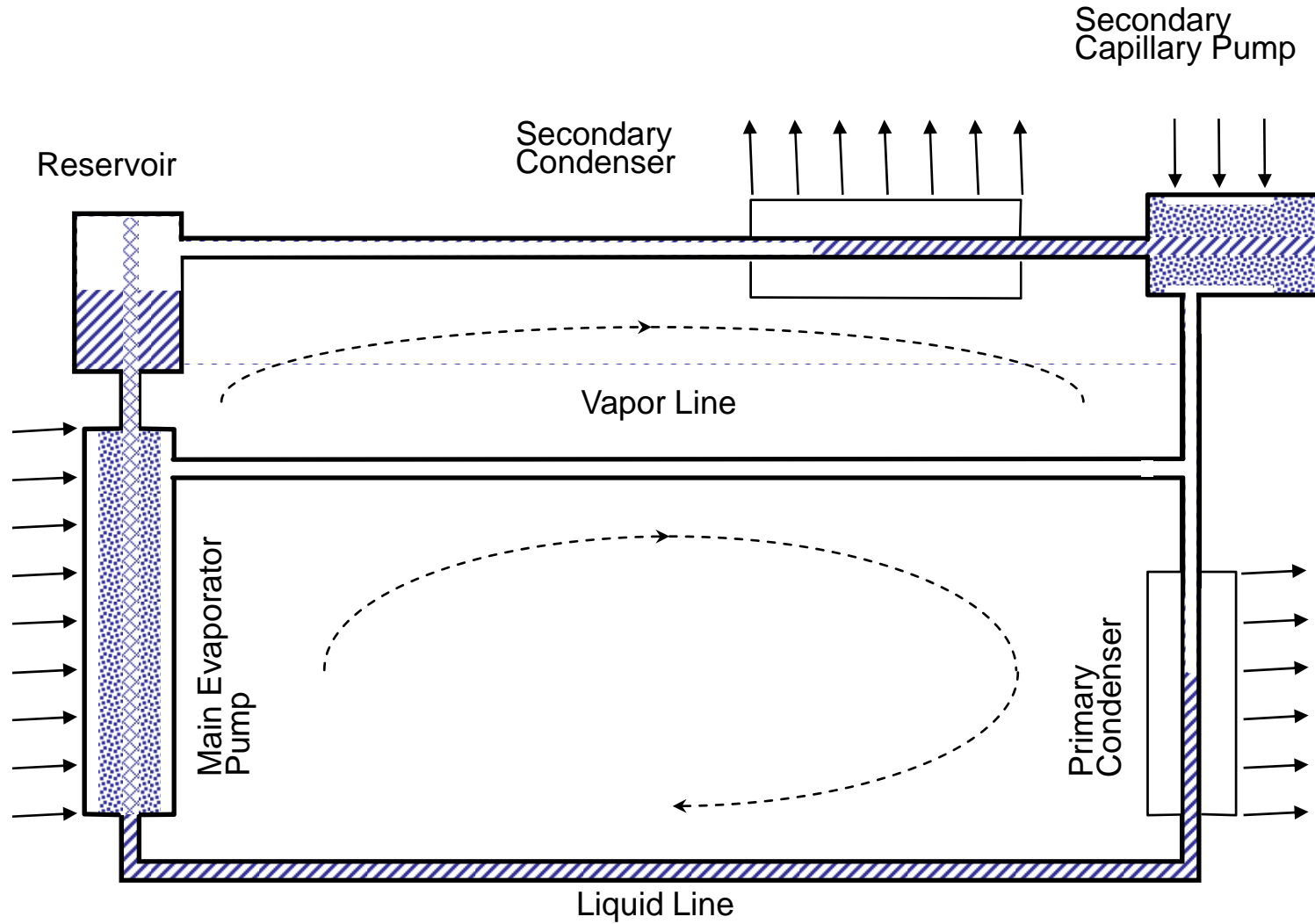

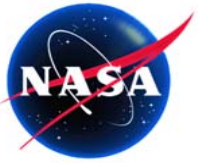

# Advance Loop Heat Pipe Operating Principle

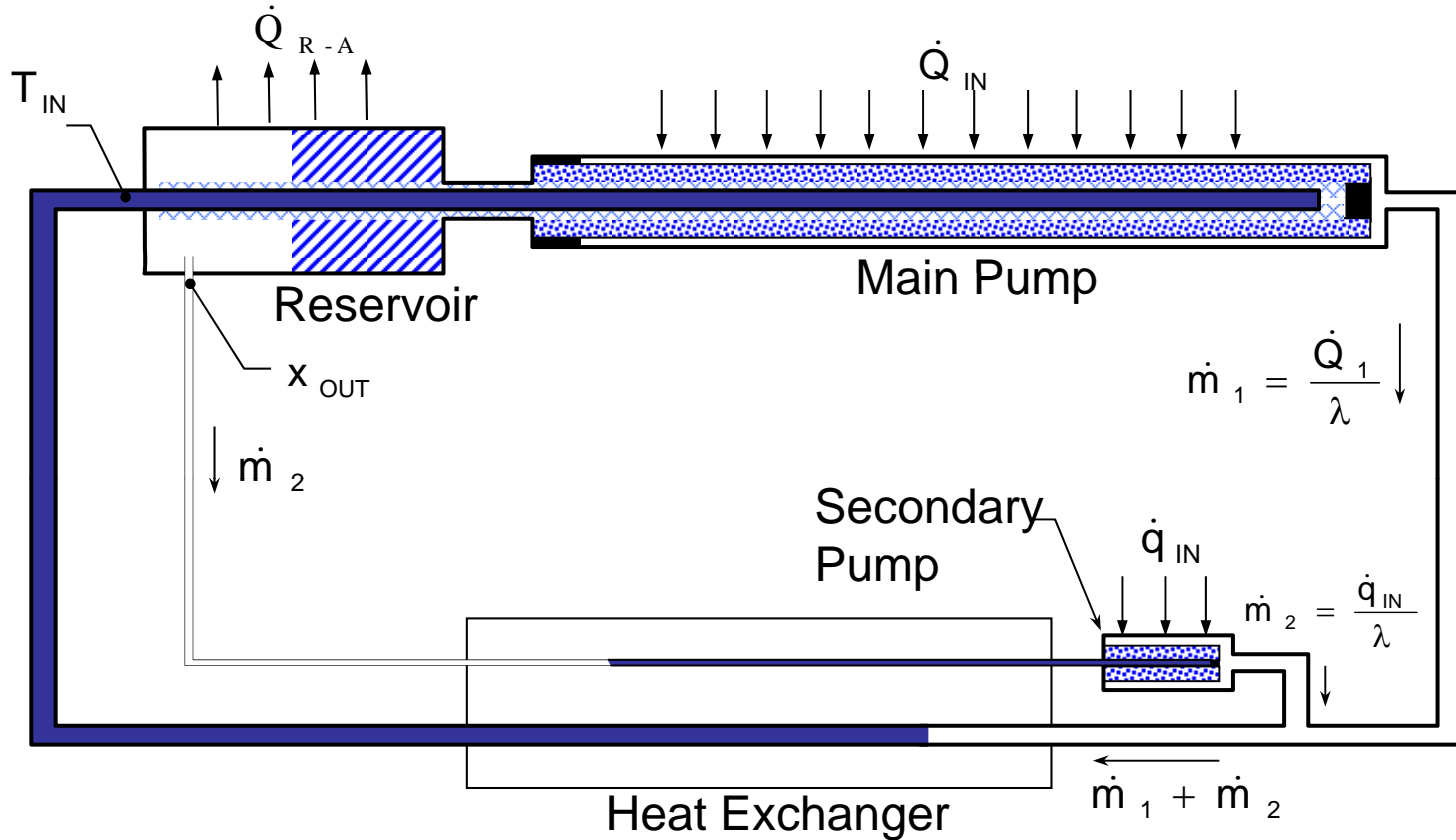

Energy Balance in Reservoir :

$$\dot{Q}_2 = \dot{m}_1 c_P \Delta T_{SC} + \dot{Q}_{R-A} + \left( \frac{c_P}{\lambda} \Delta T_{SC} + x_{OUT} \right) \dot{q}_{IN}$$

$$\Delta T_{SC} = T_{SAT} - T_{IN}$$

$x_{OUT}$  = vapor quality of removed fluid

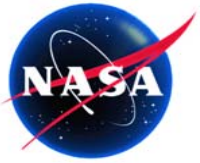

# Advanced LHP for Cryocooling

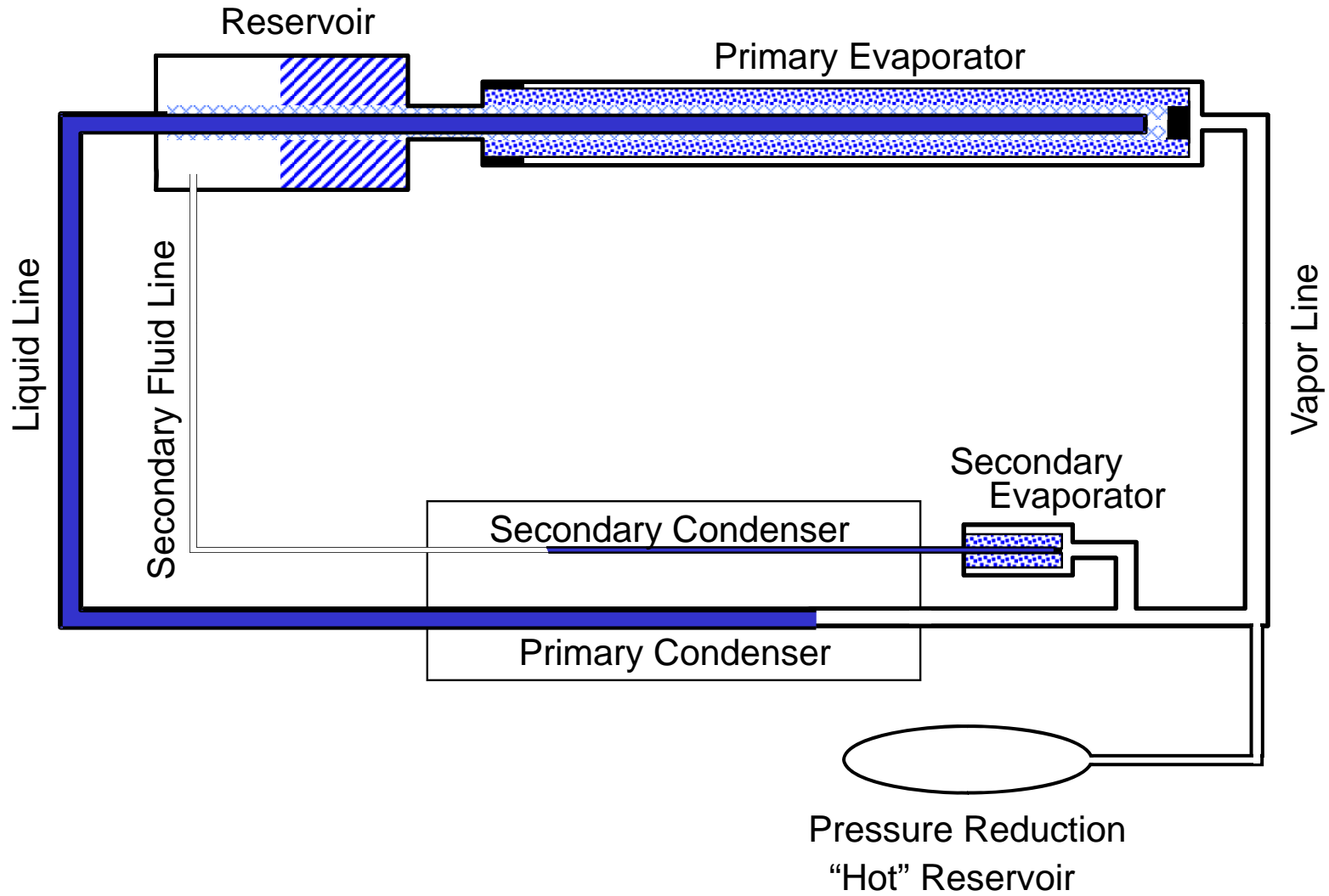

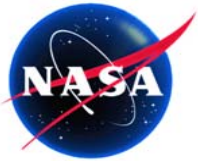

## Overcoming Technical Challenges of CLHP

- **A mismatch of coefficient of thermal expansion between the capillary pump and the primary wick**
  - **Solved by using the same material for capillary pump and primary wick**
- **Containment of the system pressure at ambient temperature**
  - **Solved by using a hot reservoir attached to the CLHP to reduce the system pressure**
- **Start-up from an initially supercritical state**
  - **Solved by using a hot reservoir to reduce the CLHP pressure below the critical pressure**
- **Parasitic heat gain at cryogenic temperatures**
  - **Solved by applying power to the secondary evaporator to cool the reservoir**



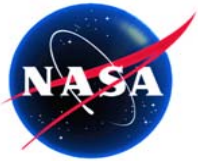

# Start-up of CLHP

**Cryocooler  
Cooldown**

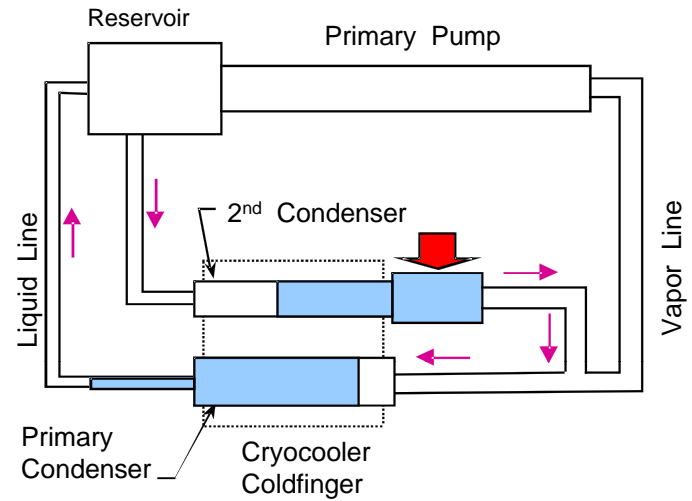
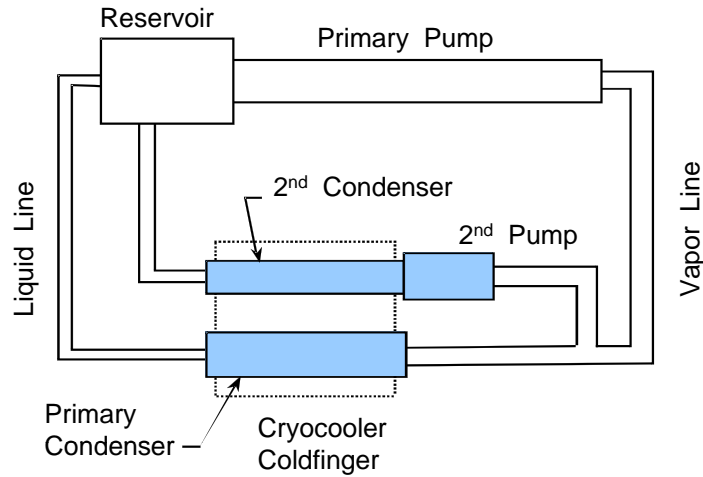

**Cooling & Pumping  
of 2<sup>nd</sup> Pump**

**Startup**

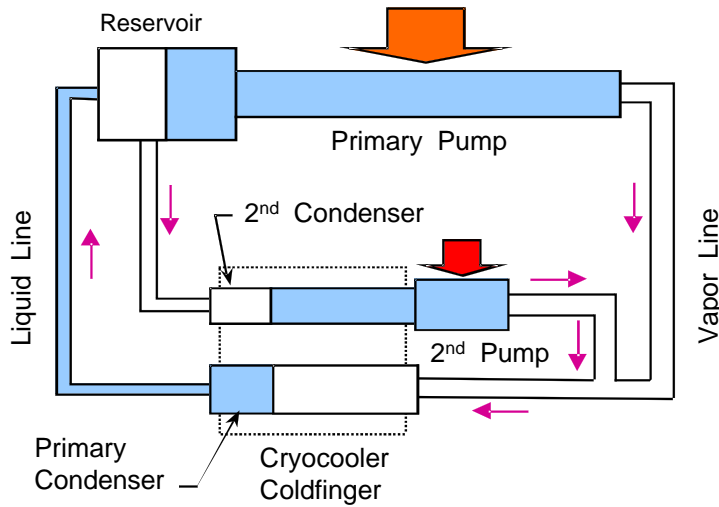

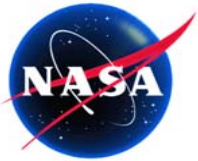

# Management of Parasitics

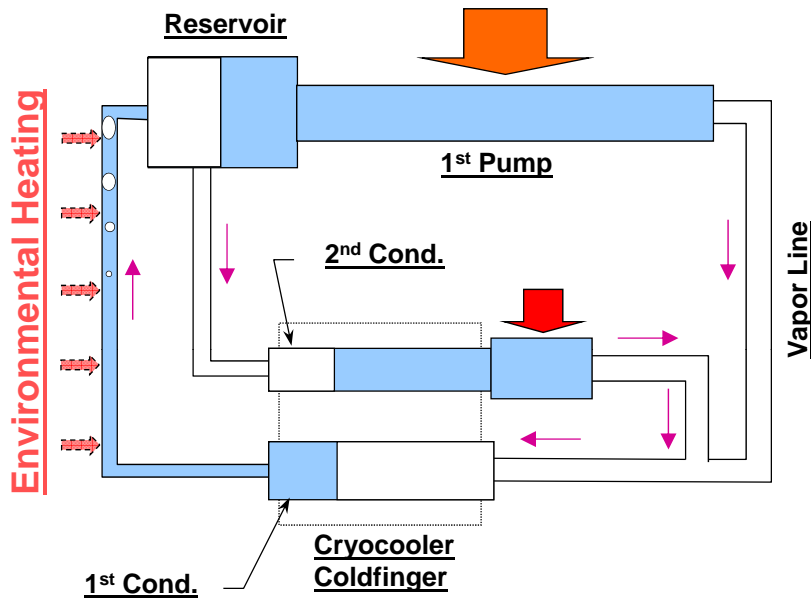

2<sup>nd</sup> Pump to Manage Parasitics

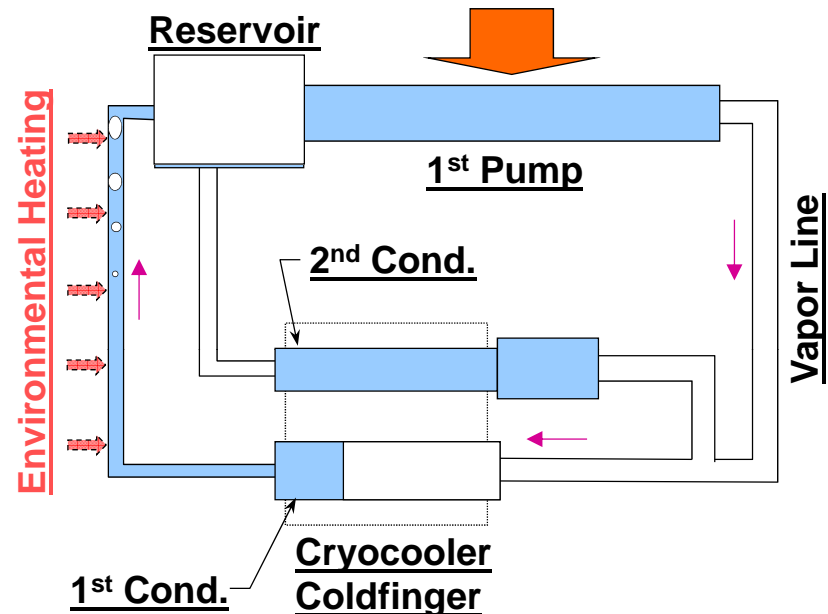

No Parasitics Management → Failure

- Environmental Heating (Parasitics) ⇒ Boiling in Liquid Line
- ⇒ Vapor Build-up in Reservoir (if not properly managed)
- ⇒ System Failure

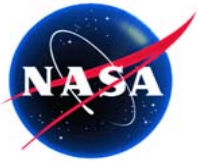

# Pressure Reduction Reservoir

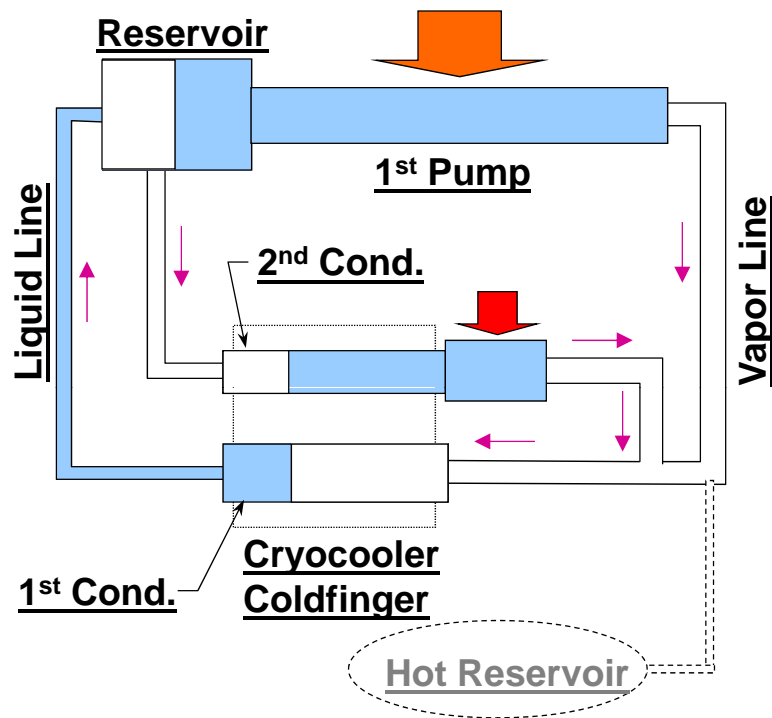

Normal Operation ( $P_{SYSTEM} < 20\text{psia}$ )

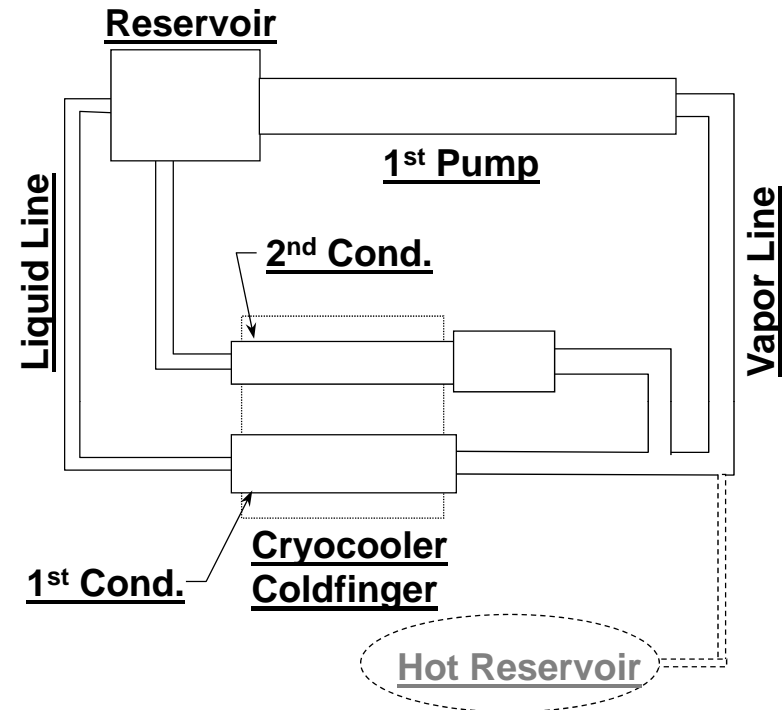

Dormancy in Hot Environment

System Pressure  $> 3,000\text{psia}$  w/o Hot Reservoir  
System Pressure  $< 100\text{psia}$  with Hot Reservoir

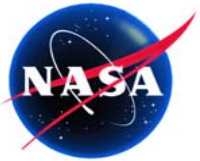

# Schematic of Advanced Hydrogen CLHP

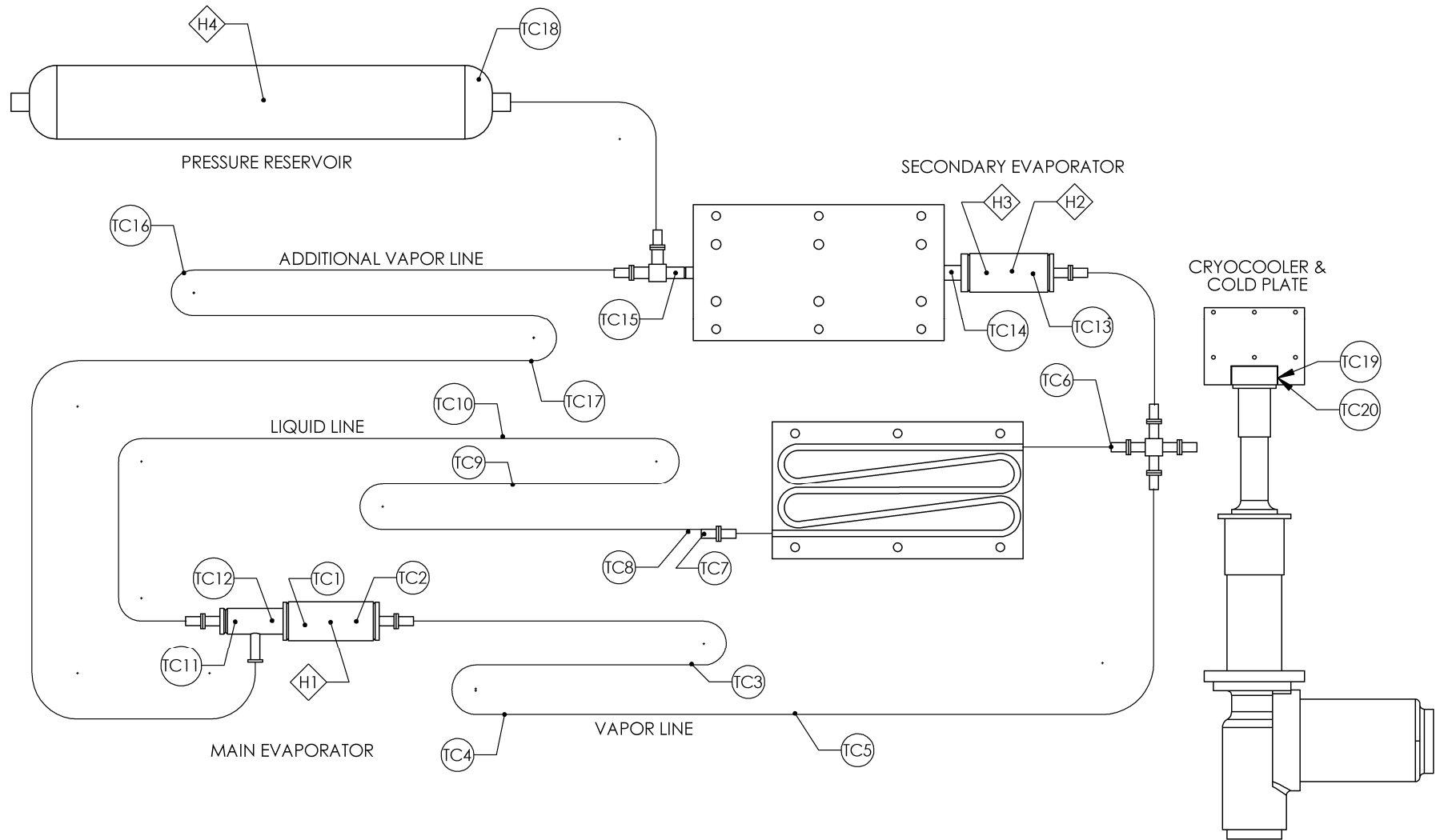
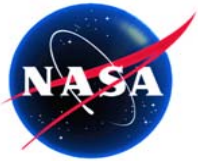
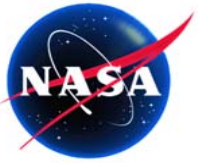

Figure 3 – Schematic of Cryogenic A-LHP



## H2-ALHP COMPONENT SIZING

<b>Component</b>	<b>Dimensions</b>
<b>Primary Evaporator</b>	
<b>Primary Wick</b>	<b>19mm OD x 4.93mm I.D. x 25.4mm L</b> <b>3 micron pore radius, 40% porosity, <math>0.5 \times 10^{-13} \text{ m}^2</math> permeability</b>
<b>Reservoir</b>	<b>19 mm OD x 25.4 mm L</b>
<b>Secondary Evaporator</b>	
<b>Wick</b> <b>Reservoir 19mm O.C.</b> <b>x12.5mmL</b>	<b>19mm OD x 4.93mm I.D. x 25.4mm L</b> <b>3 micron pore radius, 45% porosity, <math>0.5 \times 10^{-13} \text{ m}^2</math> permeability</b>
<b>Vapor Line</b>	<b>3.18 mm OD x 2.4mm ID x 2500 mm L</b>
<b>Liquid Line</b>	<b>2.38mm OD x 1.6 mm ID x 2500 mm L</b>
<b>Additional Vapor Line</b>	<b>2.28 mm OD x 1.6 mm ID x 2500 mm L</b>
<b>Serpentine Condenser Length</b>	<b>3.18 mm OD, x1.6 mm ID x 812.8 mmL</b>
<b>Length through 2<sup>nd</sup></b> <b>Condenser</b>	<b>6.35 mm OD x 4.93 mm ID x 6152.4 L</b>
<b>Pressure Reduction Reservoir</b>	<b>101.6 mm OD x 91 mm ID x 677.9 mm L</b>



## Advanced Hydrogen CLHP

- **Demonstrated successful startup and stable operation over temperature range of 20K to 30K.**



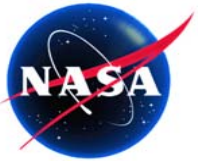

# Cooldown of Hydrogen Advanced LHP

- The cold finger, secondary condenser, secondary evaporator temperatures dropped from 280K to 30K in 4 hours.
- The primary evaporator, reservoir, vapor line, liquid line were still above 160K

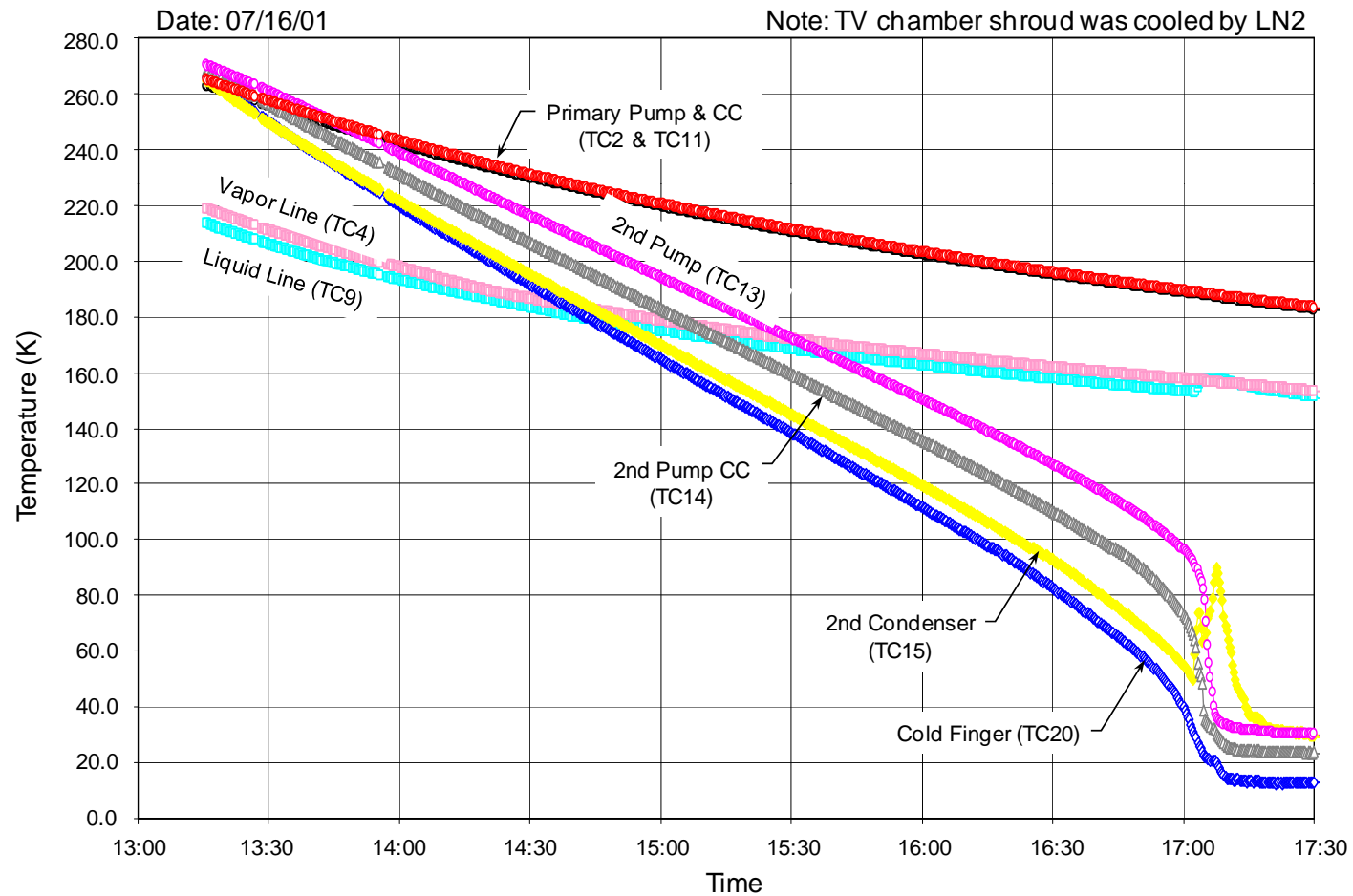

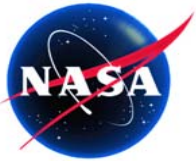

# Startup of Hydrogen Advanced LHP

- The primary evaporator, reservoir temperatures dropped below 35K after 2.5W was applied to the secondary evaporator.
- The loop started successfully by applying 5W to the primary evaporator.

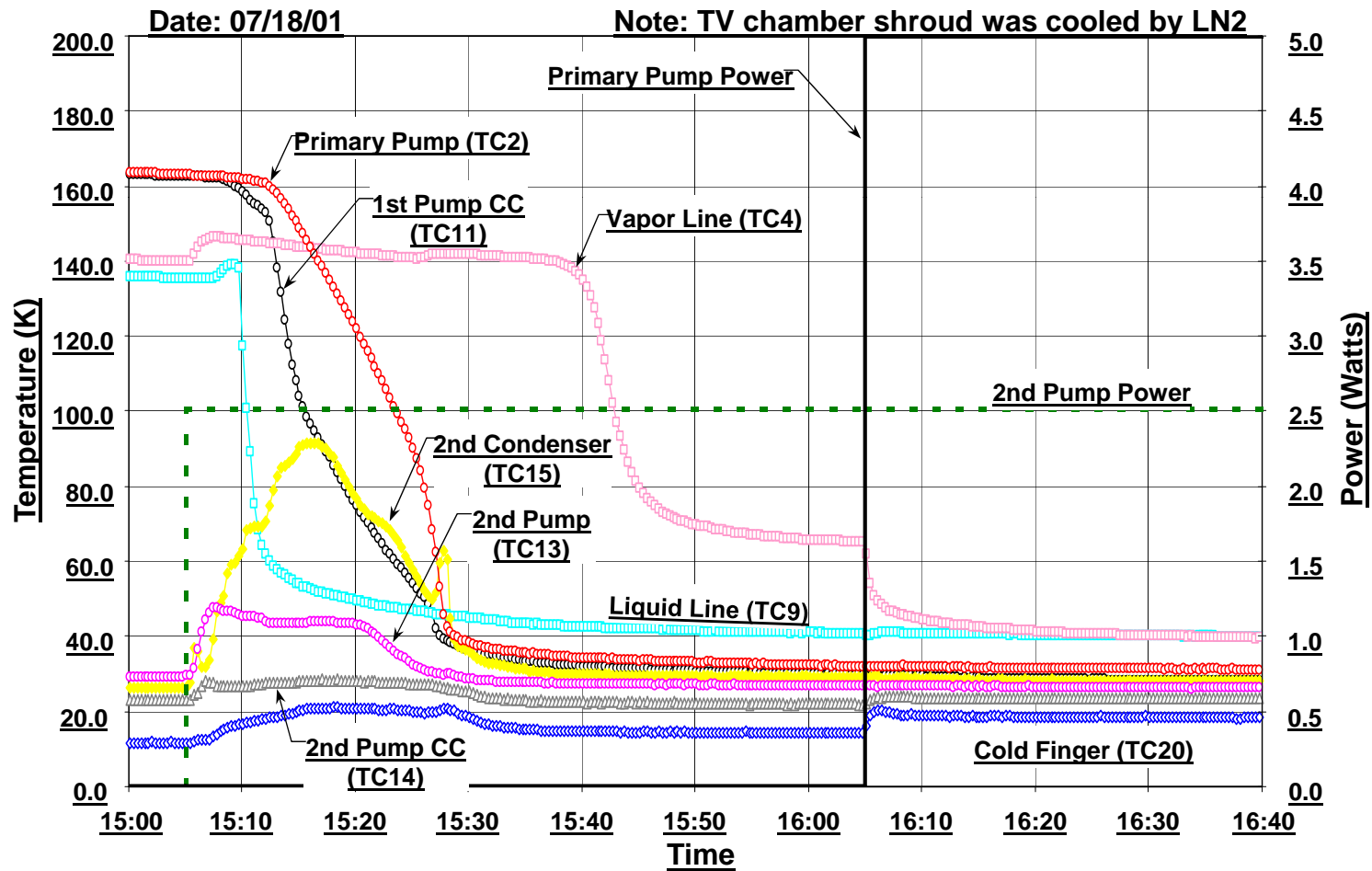



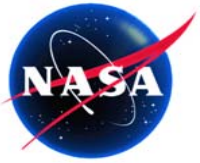

# Power Cycle Test of Hydrogen Advanced LHP

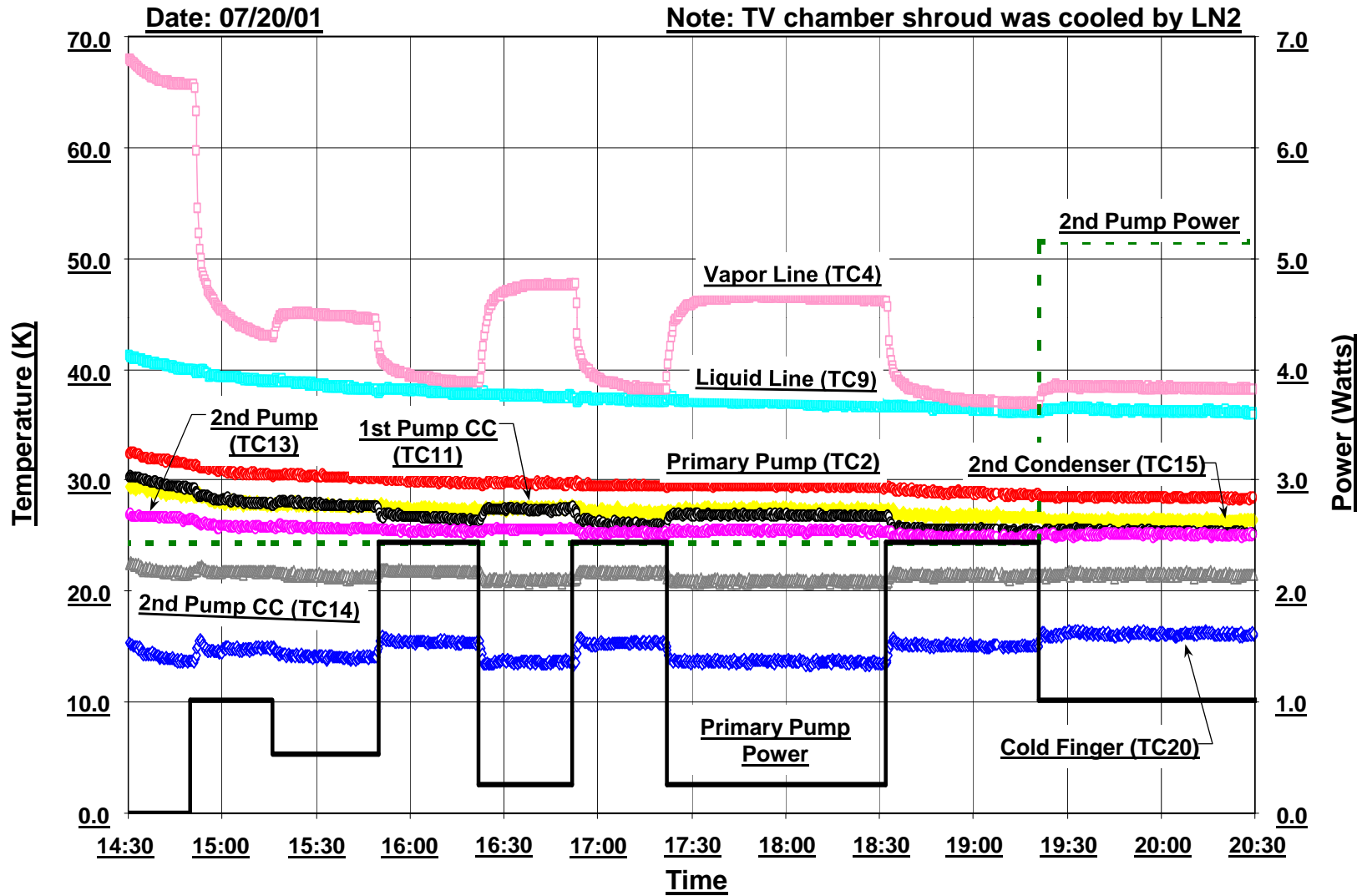

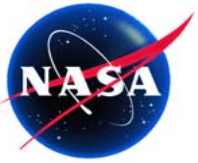

# Deprime and Recovery of Hydrogen Advanced LHP

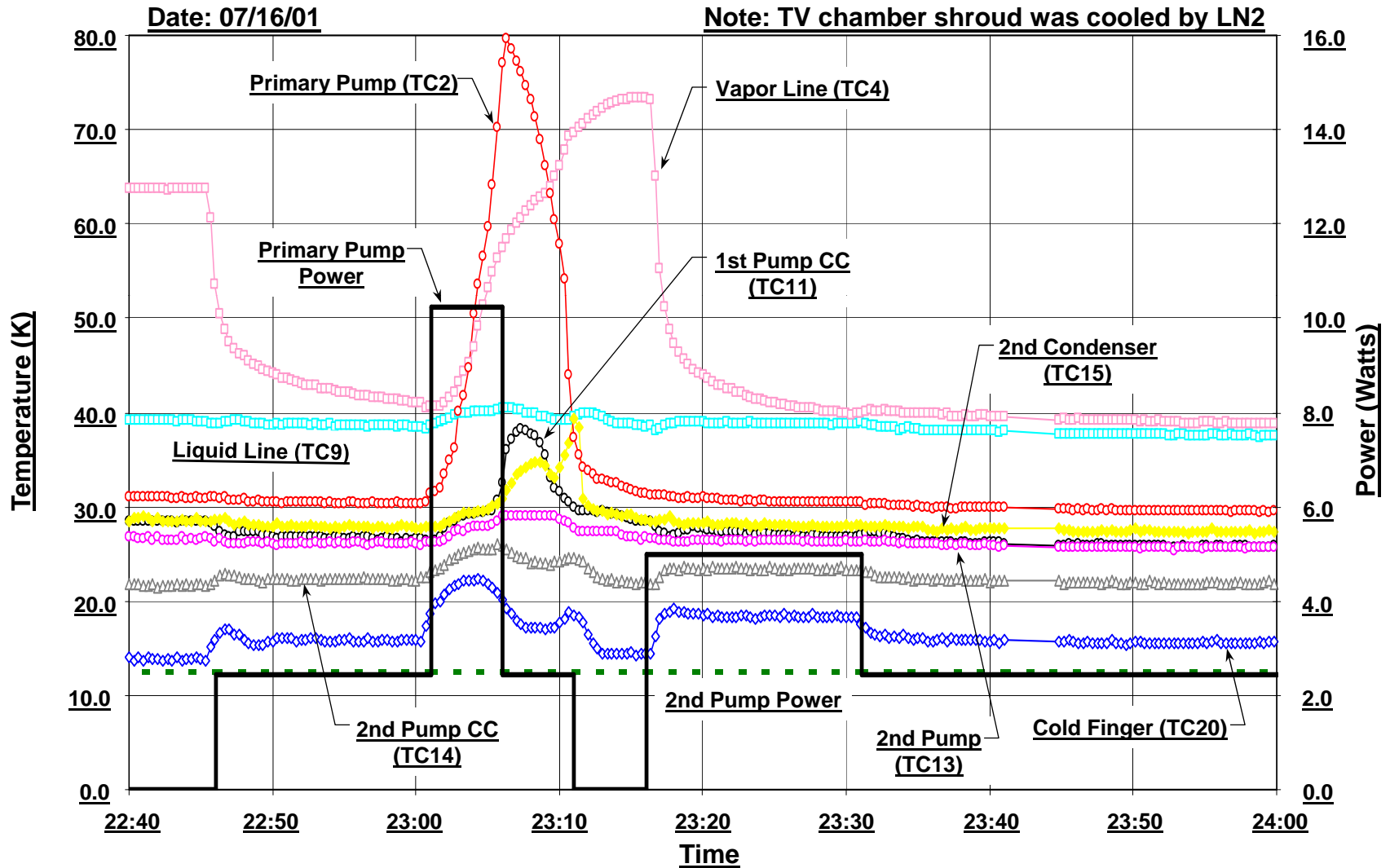

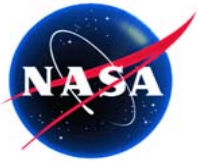

## Summary of Hydrogen Advanced LHP Operation

- **The hydrogen advanced LHP worked well in all phases of operation. It was capable of starting and functioning reliably even in a very hot (298K) surrounding shroud.**
- **The loop could transport up to 10 watts over a distance of 2.5 meters in 298K shroud.**
- **The loop operation was resilient and robust with respect to start-ups, rapid power changes, recovery from failures, and parasitics handling.**

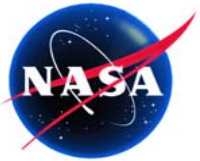

## Conclusions

- **The feasibility of an advanced LHP concept using a secondary evaporator and a hot reservoir was demonstrated.**
- **The advanced LHP can be used cryocooling using various working fluids.**
- **In addition to hydrogen advanced LHP, other cryogenic LHPs using nitrogen as the working fluid were built for across-gimbal applications. Test results also demonstrated its excellent performance.**
- **The design of the hot reservoir can be optimized.**

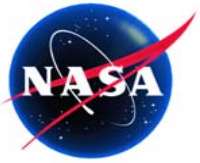

**Questions?**